



KNX B8-TH

Interface

Item number 70249



1. Description	3
1.0.1. Scope of delivery	3
1.1. Technical specifications	4
2. Installation and commissioning	4
2.1. Installation notes	4
2.2. Installation location	5
2.3. Connection	5
2.3.1. Device design	6
2.3.2. Diagram	7
2.4. Instructions for assembly and initial start-up	7
3. Addressing of the device at the bus	7
4. Transfer protocol	8
4.1. List of all communications objects	8
5. Parameter settings	19
5.1. Behaviour on power failure/ restoration of power	19
5.2. General settings	19
5.3. Temperature readings	20
5.4. Temperature threshold values	20
5.4.1. Threshold values 1...8	21
5.5. Temperature PI controller	23
5.5.1. Heating control level 1/2	29
5.5.2. Cooling control level 1/2	31
5.6. Humidity reading	33
5.7. Humidity threshold values	34
5.7.1. Threshold value 1/2	34
5.8. Humidity PI control	36
5.9. Dewpoint measurement	39
5.9.1. Coolant temperature monitoring	39
5.10. Absolute humidity	42
5.11. Comfort field	42
5.12. Variable comparator	43
5.12.1. Control variable comparator 1/2	43
5.13. Logic	44
5.13.1. AND logic 1-4 and OR logic outputs 1-4	45
5.13.2. AND logic connection inputs	47
5.13.3. OR LOGIC connection inputs	49
5.14. Pushbutton interfaces	49
5.14.1. Interface 1...8	49
5.14.2. Control modes for drive control	52



Installation, inspection, commissioning and troubleshooting of the device must only be carried out by a competent electrician.

This manual is amended periodically and will be brought into line with new software releases. The change status (software version and date) can be found in the contents footer. If you have a device with a later software version, please check **www.elsner-elektronik.de** in the menu area "Service" to find out whether a more up-to-date version of the manual is available.

Clarification of signs used in this manual



Safety advice.



Safety advice for working on electrical connections, components, etc.

DANGER!

... indicates an immediately hazardous situation which will lead to death or severe injuries if it is not avoided.

WARNING!

... indicates a potentially hazardous situation which may lead to death or severe injuries if it is not avoided.

CAUTION!

... indicates a potentially hazardous situation which may lead to trivial or minor injuries if it is not avoided.



ATTENTION! ... indicates a situation which may lead to damage to property if it is not avoided.

ETS

In the ETS tables, the parameter default settings are marked by underlining.

1. Description

The **Interface KNX B8-TH** has eight binary inputs and two additional sensor inputs for temperature and humidity as well as temperature and air humidity. They are used to integrate signals and values from conventional buttons and sensors into the KNX building bus.

The application software of the **Interface KNX B8-TH** contains both switch outputs for temperature and humidity as well as PI controllers for heating/cooling and ventilation. The binary inputs can be configured as switches, up/down buttons, dimmers or encoders in various configurations.

Due to its compact design, the interface fits into a switch box. The binary contacts are connected using the cables supplied with the delivery.

Functions:

- **8 binary inputs** (button interfaces for potential-free contacts)
- **1 input for temperature sensor** T-UP basic or **temperature/air humidity sensor** TH-UP basic. Sensors for wall mounting in 55 mm standard frames of switch programmes
- **1 input for temperature sensor** T-NTC-ST
- Bus warning with regard to whether the values for temperature and air humidity are within the comfort field (DIN 1946).
- Dewpoint calculation
- Switch outputs for temperature and air humidity depending on threshold values, adjustable via parameters or communication objects.
- **PI-controller for heating** (one or two-stage) and **cooling** (one or two-stage) according to temperature. Regulation according to separate setpoints or basic setpoint temperature
- **PI controller for humidity** according to humidity: Dehumidifying/humidifying (single level) or dehumidifying (single or double level)
- **4 AND and 4 OR logic gates**, each with 4 inputs. All switching events as well as 16 logic inputs (in the form of communications objects) can be used as inputs for the logic gates. The output of each gate can be configured optionally as 1-bit or 2 x 8-bit

Configuration is made using the KNX software ETS. The **product file** can be downloaded from the Elsner Elektronik website on www.elsner-elektronik.de in the "Service" menu.

1.0.1. Scope of delivery

- Interface
- 2 eight-wire connection lines for binary inputs (length approx. 30 cm)

1.1. Technical specifications

Housing	Plastic
Colour	White
Assembly	Installation
Protection category	IP 20
Dimensions	approx. 38 x 49 x 18 (W x H x D, mm)
Weight	approx. 20 g (interface) approx. 30 g (interface incl. connection lines)
Ambient temperature	Operation -20...+70 °C, storage -55...+150 °C
Ambient humidity	max. 95 % RH, avoid condensation
Operating voltage	KNX bus voltage
Power	10 mA on the bus
Inputs	8x binary (connection lines approx. 0.3 m, extendable to a maximum of 10 m). 1x sensor T-UP basic, no. 30520 (max. output length 10 m) or TH-UP basic, no. 30525 (max. output length 0.3 m). 1x temperature sensor T-NTC-ST, no. 30513 (max. output length 10 m).
Data output	KNX +/- bus plug-in terminals
BCU type	Integrated microcontroller
PEI type	0
Group addresses	max. 254
Assignments	max. 254
Communication objects	254

The product conforms with the provisions of EU directives.

2. Installation and commissioning

2.1. Installation notes



Installation, testing, operational start-up and troubleshooting should only be performed by an electrician.



CAUTION! **Live voltage!**

There are unprotected live components inside the device.

- National legal regulations are to be followed.
- Ensure that all lines to be assembled are free of voltage and take precautions against accidental switching on.

- Do not use the device if it is damaged.
- Take the device or system out of service and secure it against unintentional use, if it can be assumed, that risk-free operation is no longer guaranteed.

The device is only to be used for its intended purpose. Any improper modification or failure to follow the operating instructions voids any and all warranty and guarantee claims.

After unpacking the device, check it immediately for possible mechanical damage. If it has been damaged in transport, inform the supplier immediately.

The device may only be used as a fixed-site installation; that means only when assembled and after conclusion of all installation and operational start-up tasks and only in the surroundings designated for it.

Elsner Elektronik is not liable for any changes in norms and standards which may occur after publication of these operating instructions.

2.2. Installation location



The device may only be installed and operated in dry, indoor spaces. Avoid condensation.

2.3. Connection

The **Interface KNX B8-TH** is connected to the KNX data bus with a KNX connection terminal. The physical address is assigned by the KNX software. There is a button with a control LED for this on the device.

Binary contacts are connected to the inputs IN1 to IN8 with the connection lines included in the delivery.

The temperature and humidity sensor TH-UP basic or the temperature sensor T-UP basic (for 55 mm switch programmes) is connected to the input T(H)-UP basis.

The temperature sensor T-NTC-ST (plug/contact sensor) is plugged into the input T-NTC-ST.

2.3.1. Device design

III. 1

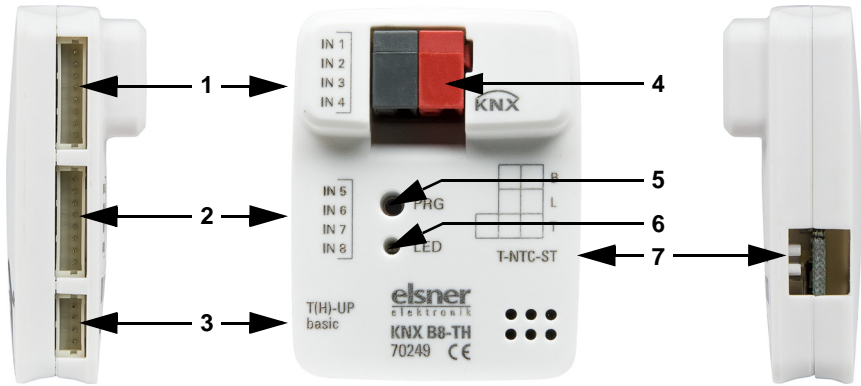

- 1 Connection binary inputs 1-4
- 2 Connection binary inputs 5-8
- 3 Connection sensor T-UP basic or TH-UP basic
- 4 KNX plug terminal +/-

- 5 Programming key (recessed)
- 6 Programming LED (recessed)
- 7 Connection temperature sensor T-NTC-ST

III. 2

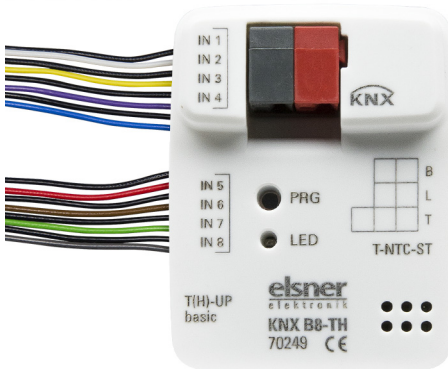

The device is delivered with connection lines for the binary inputs.
 IN1: black/white
 IN2: black/yellow
 IN3: black/purple
 IN4: black/blue
 IN5: black/red
 IN6: black/brown
 IN7: black/green
 IN8: black/grey

2.3.2. Diagram

III. 3

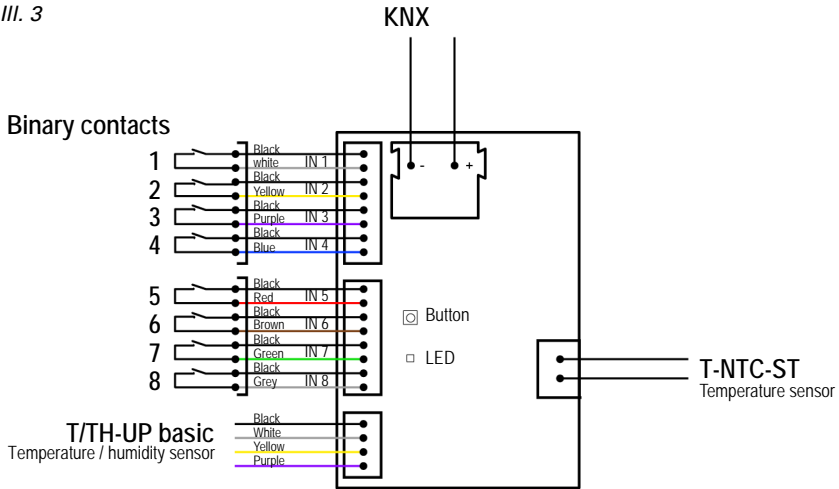

2.4. Instructions for assembly and initial start-up

Never expose the sensor to water (e.g. rain) or dust. This can damage the electronics. You must not exceed a relative air humidity of 95%. Avoid condensation.

After the bus voltage has been applied, the unit will enter an initialisation phase lasting a few seconds. During this phase no information can be received via the bus.

3. Addressing of the device at the bus

The device is supplied with the bus address 15.15.250. You can program another address into the ETS by overwriting the 15.15.250 address or by teaching via the programming key.

4. Transfer protocol

Units:

Temperatures in degrees Celsius

Air humidity in %

Absolute air humidity in g/kg and/or g/m³

Variables in %

4.1. List of all communications objects

Abbreviation flags:

C Communication

R Read

W Write

T Transfer

U Update

No.	Text	Function	Flags	DPT type	Size
0	Software version	Output	R-CT	[217.1] DPT_Version	2 bytes
1	Plug-in sensor: Malfunction	Output	R-CT	[1.1] DPT_Switch	1 bit
2	Temp. plug-in sensor: External reading	Input	-WCT	[9.1] DPT_Val- ue_Temp	2 bytes
3	Temp. plug-in sensor: Reading	Output	R-CT	[9.1] DPT_Val- ue_Temp	2 bytes
4	Temp. plug-in sensor: Total reading	Output	R-CT	[9.1] DPT_Val- ue_Temp	2 bytes
5	Temp. plug-in sensor: Min./ max. reading query	Input	-WC-	[1.17] DPT_Trigger	1 bit
6	Temp. plug-in sensor: Minimum reading	Output	R-CT	[9.1] DPT_Val- ue_Temp	2 bytes
7	Temp. plug-in sensor: Maximum reading	Output	R-CT	[9.1] DPT_Val- ue_Temp	2 bytes
8	Temp. plug-in sensor: Min./ max. reading reset	Input	-WC-	[1.17] DPT_Trigger	1 bit
9	Board sensor: Malfunction	Output	R-CT	[1.1] DPT_Switch	1 bit
10	Temp. board sensor: External reading	Input	-WCT	[9.1] DPT_Val- ue_Temp	2 bytes
11	Temp. board sensor: Reading	Output	R-CT	[9.1] DPT_Val- ue_Temp	2 bytes
12	Temp. board sensor: Total reading	Output	R-CT	[9.1] DPT_Val- ue_Temp	2 bytes
13	Temp. board sensor: Min./ max. reading query	Input	-WC-	[1.17] DPT_Trigger	1 bit

No.	Text	Function	Flags	DPT type	Size
14	Temp. board sensor: Minimum reading	Output	R-CT	[9.1] DPT_Val- ue_Temp	2 bytes
15	Temp. board sensor: Maximum reading	Output	R-CT	[9.1] DPT_Val- ue_Temp	2 bytes
16	Temp. board sensor: Min./ max. reading reset	Input	-WC-	[1.17] DPT_Trigger	1 bit
17	Temp. threshold value 1: Absolute value	Input / Output	RWCT	[9.1] DPT_Val- ue_Temp	2 bytes
18	Temp. threshold value 1: (1:+ 0:-)	Input	-WC-	[1.1] DPT_Switch	1 bit
19	Temp. threshold value 1: Switching delay from 0 to 1	Input	-WC-	[7.5] DPT_TimePeri- odSec	2 bytes
20	Temp. threshold value 1: Switching delay from 1 to 0	Input	-WC-	[7.5] DPT_TimePeri- odSec	2 bytes
21	Temp. threshold value 1: Switching output	Output	R-CT	[1.1] DPT_Switch	1 bit
22	Temp. threshold value 1: Switching output block	Input	-WC-	[1.1] DPT_Switch	1 bit
23	Temp. threshold value 2: Absolute value	Input / Output	RWCT	[9.1] DPT_Val- ue_Temp	2 bytes
24	Temp. threshold value 2: (1:+ 0:-)	Input	-WC-	[1.1] DPT_Switch	1 bit
25	Temp. threshold value 2: Switching delay from 0 to 1	Input	-WC-	[7.5] DPT_TimePeri- odSec	2 bytes
26	Temp. threshold value 2: Switching delay from 1 to 0	Input	-WC-	[7.5] DPT_TimePeri- odSec	2 bytes
27	Temp. threshold value 2: Switching output	Output	R-CT	[1.1] DPT_Switch	1 bit
28	Temp. threshold value 2: Switching output block	Input	-WC-	[1.1] DPT_Switch	1 bit
29	Temp. threshold value 3: Absolute value	Input / Output	RWCT	[9.1] DPT_Val- ue_Temp	2 bytes
30	Temp. threshold value 3: (1:+ 0:-)	Input	-WC-	[1.1] DPT_Switch	1 bit
31	Temp. threshold value 3: Switching delay from 0 to 1	Input	-WC-	[7.5] DPT_TimePeri- odSec	2 bytes
32	Temp. threshold value 3: Switching delay from 1 to 0	Input	-WC-	[7.5] DPT_TimePeri- odSec	2 bytes
33	Temp. threshold value 3: Switching output	Output	R-CT	[1.1] DPT_Switch	1 bit
34	Temp. threshold value 3: Switching output block	Input	-WC-	[1.1] DPT_Switch	1 bit
35	Temp. threshold value 4: Absolute value	Input / Output	RWCT	[9.1] DPT_Val- ue_Temp	2 bytes

No.	Text	Function	Flags	DPT type	Size
36	Temp. threshold value 4: (1:+ 0:-)	Input	-WC-	[1.1] DPT_Switch	1 bit
37	Temp. threshold value 4: Switching delay from 0 to 1	Input	-WC-	[7.5] DPT_TimePeriodSec	2 bytes
38	Temp. threshold value 4: Switching delay from 1 to 0	Input	-WC-	[7.5] DPT_TimePeriodSec	2 bytes
39	Temp. threshold value 4: Switching output	Output	R-CT	[1.1] DPT_Switch	1 bit
40	Temp. threshold value 4: Switching output block	Input	-WC-	[1.1] DPT_Switch	1 bit
41	Temp. threshold value 5: Absolute value	Input / Output	RWCT	[9.1] DPT_ValueTemp	2 bytes
42	Temp. threshold value 5: (1:+ 0:-)	Input	-WC-	[1.1] DPT_Switch	1 bit
43	Temp. threshold value 5: Switching delay from 0 to 1	Input	-WC-	[7.5] DPT_TimePeriodSec	2 bytes
44	Temp. threshold value 5: Switching delay from 1 to 0	Input	-WC-	[7.5] DPT_TimePeriodSec	2 bytes
45	Temp. threshold value 5: Switching output	Output	R-CT	[1.1] DPT_Switch	1 bit
46	Temp. threshold value 5: Switching output block	Input	-WC-	[1.1] DPT_Switch	1 bit
47	Temp. threshold value 6: Absolute value	Input / Output	RWCT	[9.1] DPT_ValueTemp	2 bytes
48	Temp. threshold value 6: (1:+ 0:-)	Input	-WC-	[1.1] DPT_Switch	1 bit
49	Temp. threshold value 6: Switching delay from 0 to 1	Input	-WC-	[7.5] DPT_TimePeriodSec	2 bytes
50	Temp. threshold value 6: Switching delay from 1 to 0	Input	-WC-	[7.5] DPT_TimePeriodSec	2 bytes
51	Temp. threshold value 6: Switching output	Output	R-CT	[1.1] DPT_Switch	1 bit
52	Temp. threshold value 6: Switching output block	Input	-WC-	[1.1] DPT_Switch	1 bit
53	Temp. threshold value 7: Absolute value	Input / Output	RWCT	[9.1] DPT_ValueTemp	2 bytes
54	Temp. threshold value 7: (1:+ 0:-)	Input	-WC-	[1.1] DPT_Switch	1 bit
55	Temp. threshold value 7: Switching delay from 0 to 1	Input	-WC-	[7.5] DPT_TimePeriodSec	2 bytes
56	Temp. threshold value 7: Switching delay from 1 to 0	Input	-WC-	[7.5] DPT_TimePeriodSec	2 bytes
57	Temp. threshold value 7: Switching output	Output	R-CT	[1.1] DPT_Switch	1 bit

No.	Text	Function	Flags	DPT type	Size
58	Temp. threshold value 7: Switching output block	Input	-WC-	[1.1] DPT_Switch	1 bit
59	Temp. threshold value 8: Absolute value	Input / Output	RWCT	[9.1] DPT_Value_Temp	2 bytes
60	Temp. threshold value 8: (1:+ 0:-)	Input	-WC-	[1.1] DPT_Switch	1 bit
61	Temp. threshold value 8: Switching delay from 0 to 1	Input	-WC-	[7.5] DPT_TimePeriodSec	2 bytes
62	Temp. threshold value 8: Switching delay from 1 to 0	Input	-WC-	[7.5] DPT_TimePeriodSec	2 bytes
63	Temp. threshold value 8: Switching output	Output	R-CT	[1.1] DPT_Switch	1 bit
64	Temp. threshold value 8: Switching output block	Input	-WC-	[1.1] DPT_Switch	1 bit
65	Temp. controller: HVAC mode (priority 1)	Input	-WC-	[20.102] DPT_HVAC-Mode	1 byte
66	Temp. controller: HVAC mode (priority 2)	Input	RWCT	[20.102] DPT_HVAC-Mode	1 byte
67	Temp. controller: Frost/heat protection mode activation	Input	RWCT	[1.1] DPT_Switch	1 bit
68	Temp. controller: Block (1 = Blocking)	Input	-WC-	[1.1] DPT_Switch	1 bit
69	Temp. controller: Current setpoint	Output	R-CT	[9.1] DPT_Value_Temp	2 bytes
70	Temp. controller: Switching (0: Heating 1: Cooling)	Input	-WC-	[1.1] DPT_Switch	1 bit
71	Temp. controller: Comfort heating setpoint	Input / Output	RWCT	[9.1] DPT_Value_Temp	2 bytes
72	Temp. controller: Comfort heating setpoint (1:+ 0: -)	Input	-WC-	[1.1] DPT_Switch	1 bit
73	Temp. controller: Comfort cooling setpoint	Input / Output	RWCT	[9.1] DPT_Value_Temp	2 bytes
74	Temp. controller: Comfort cooling setpoint (1:+ 0: -)	Input	-WC-	[1.1] DPT_Switch	1 bit
75	Temp. controller: Basic 16-bit setpoint shift	Input / Output	RWCT	[9.1] DPT_Value_Temp	2 bytes
76	Temp. controller: Standby heating setpoint	Input / Output	RWCT	[9.1] DPT_Value_Temp	2 bytes
77	Temp. controller: Standby heating setpoint (1:+ 0: -)	Input	-WC-	[1.1] DPT_Switch	1 bit
78	Temp. controller: Standby cooling setpoint	Input / Output	RWCT	[9.1] DPT_Value_Temp	2 bytes

No.	Text	Function	Flags	DPT type	Size
79	Temp. controller: Standby cooling setpoint (1:+ 0: -)	Input	-WC-	[1.1] DPT_Switch	1 bit
80	Temp. controller: Eco heating setpoint	Input / Output	RWCT	[9.1] DPT_Value_Temp	2 bytes
81	Temp. controller: Eco heating setpoint (1:+ 0: -)	Input	-WC-	[1.1] DPT_Switch	1 bit
82	Temp. controller: Eco cooling setpoint	Input / Output	RWCT	[9.1] DPT_Value_Temp	2 bytes
83	Temp. controller: Eco cooling setpoint (1:+ 0: -)	Input	-WC-	[1.1] DPT_Switch	1 bit
84	Temp. controller: Heating control variable (level 1)	Output	R-CT	[5.1] DPT_Scaling	1 byte
85	Temp. controller: Heating control variable (level 2)	Output	R-CT	[5.1] DPT_Scaling	1 byte
86	Temp. controller: Cooling control variable (level 1)	Output	R-CT	[5.1] DPT_Scaling	1 byte
87	Temp. controller: Cooling control variable (level 2)	Output	R-CT	[5.1] DPT_Scaling	1 byte
88	Temperature controller Control variable for 4/6-way valve	Output	R-CT	[5.1] DPT_Scaling	1 byte
89	Temp. controller: Level 1 heating status (1=ON 0=OFF)	Output	R-CT	[1.1] DPT_Switch	1 bit
90	Temp. controller: Level 2 heating status (1=ON 0=OFF)	Output	R-CT	[1.1] DPT_Switch	1 bit
91	Temp. controller: Level 1 cooling status (1=ON 0=OFF)	Output	R-CT	[1.1] DPT_Switch	1 bit
92	Temp. controller: Level 2 cooling status (1=ON 0=OFF)	Output	R-CT	[1.1] DPT_Switch	1 bit
93	Temp. controller: Comfort extension status	Input / Output	RWCT	[1.1] DPT_Switch	1 bit
94	Temp. controller: Comfort extension time	Input	RWCT	[7.5] DPT_TimePeriodSec	2 bytes
95	Humidity sensor: External reading	Input	-WCT	[9.7] DPT_Value_Humidity	2 bytes
96	Humidity sensor: Reading	Output	R-CT	[9.7] DPT_Value_Humidity	2 bytes
97	Humidity sensor: Total reading	Output	R-CT	[9.7] DPT_Value_Humidity	2 bytes
98	Humidity sensor: Min./max. reading query	Input	-WC-	[1.17] DPT_Trigger	1 bit

No.	Text	Function	Flags	DPT type	Size
99	Humidity sensor: Minimum reading	Output	R-CT	[9.7] DPT_Value_Humidity	2 bytes
100	Humidity sensor: Maximum reading	Output	R-CT	[9.7] DPT_Value_Humidity	2 bytes
101	Humidity sensor: Min./max. reading reset	Input	-WC-	[1.17] DPT_Trigger	1 bit
102	Humidity threshold value 1: Absolute value	Input / Output	RWCT	[9.7] DPT_Value_Humidity	2 bytes
103	Humidity threshold value 1: (1:+ 0:-)	Input	-WC-	[1.1] DPT_Switch	1 bit
104	Humidity threshold value 1: Delay from 0 to 1	Input	-WC-	[7.5] DPT_TimePeriodSec	2 bytes
105	Humidity threshold value 1: Delay from 1 to 0	Input	-WC-	[7.5] DPT_TimePeriodSec	2 bytes
106	Humidity threshold value 1: Switching output	Output	R-CT	[1.1] DPT_Switch	1 bit
107	Humidity threshold value 1: Switching output block	Input	-WC-	[1.1] DPT_Switch	1 bit
108	Humidity threshold value 2: Absolute value	Input / Output	RWCT	[9.7] DPT_Value_Humidity	2 bytes
109	Humidity threshold value 2: (1:+ 0:-)	Input	-WC-	[1.1] DPT_Switch	1 bit
110	Humidity threshold value 2: Delay from 0 to 1	Input	-WC-	[7.5] DPT_TimePeriodSec	2 bytes
111	Humidity threshold value 2: Delay from 1 to 0	Input	-WC-	[7.5] DPT_TimePeriodSec	2 bytes
112	Humidity threshold value 2: Switching output	Output	R-CT	[1.1] DPT_Switch	1 bit
113	Humidity threshold value 2: Switching output block	Input	-WC-	[1.1] DPT_Switch	1 bit
114	Humidity controller: Block (1: block)	Input	-WC-	[1.2] DPT_Bool	1 bit
115	Humidity controller: Target value	Input / Output	RWCT	[9.7] DPT_Value_Humidity	2 bytes
116	Humidity controller: Setpoint (1:+ 0:-)	Input	-WC-	[1.2] DPT_Bool	1 bit
117	Humidity controller: Variable dehumidification actuator	Output	R-CT	[5.1] DPT_Scaling	1 byte
118	Humidity controller: Level 2 dehumidification actuator variable	Output	R-CT	[5.1] DPT_Scaling	1 byte
119	Humidity controller: Variable humidification actuator	Output	R-CT	[5.1] DPT_Scaling	1 byte

No.	Text	Function	Flags	DPT type	Size
120	Humidity controller: Dehumidification status (1:ON 0:OFF)	Output	R-CT	[1.1] DPT_Switch	1 bit
121	Humidity controller: Dehumidification 2 status (1:ON 0:OFF)	Output	R-CT	[1.1] DPT_Switch	1 bit
122	Humidity controller: Humidification status (1:ON 0:OFF)	Output	R-CT	[1.1] DPT_Switch	1 bit
123	Dewpoint: Reading	Output	R-CT	[9.1] DPT_Val- ue_Temp	2 bytes
124	Coolant temp.: Threshold value	Output	R-CT	[9.1] DPT_Val- ue_Temp	2 bytes
125	Coolant temp.: Actual value	Input	RWCT	[9.1] DPT_Val- ue_Temp	2 bytes
126	Coolant temp.: Offset change (1:+ 0:-)	Input	-WC-	[1.1] DPT_Switch	1 bit
127	Coolant temp.: Current offset	Output	R-CT	[9.1] DPT_Val- ue_Temp	2 bytes
128	Coolant temp.: Switching delay from 0 to 1	Input	-WC-	[7.5] DPT_TimePeri- odSec	2 bytes
129	Coolant temp.: Switching delay from 1 to 0	Input	-WC-	[7.5] DPT_TimePeri- odSec	2 bytes
130	Coolant temp.: Switching output	Output	R-CT	[1.1] DPT_Switch	1 bit
131	Coolant temp.: Switching output block	Input	-WC-	[1.1] DPT_Switch	1 bit
132	Absolute humidity [g/kg]	Output	R-CT	[14.5] DPT_Val- ue_Amplitude	4 bytes
133	Absolute humidity [g/m ³]	Output	R-CT	[14.17] DPT_Val- ue_Density	4 bytes
134	Ambient climate status: 1 = comfortable 0 = uncomfortable	Output	R-CT	[1.1] DPT_Switch	1 bit
135	Ambient climate status: Text	Output	R-CT	[16.0] DPT_String_ASCII	14 bytes
136	Actuating variable comparator 1: Input 1	Input	-WC-	[5.1] DPT_Scaling	1 byte
137	Actuating variable comparator 1: Input 2	Input	-WC-	[5.1] DPT_Scaling	1 byte
138	Actuating variable comparator 1: Input 3	Input	-WC-	[5.1] DPT_Scaling	1 byte
139	Actuating variable comparator 1: Input 4	Input	-WC-	[5.1] DPT_Scaling	1 byte

No.	Text	Function	Flags	DPT type	Size
140	Actuating variable comparator 1: Input 5	Input	-WC-	[5.1] DPT_Scaling	1 byte
141	Actuating variable comparator 1: Output	Output	R-CT	[5.1] DPT_Scaling	1 byte
142	Actuating variable comparator 1: Block (1: block)	Output	-WC-	[1.2] DPT_Bool	1 bit
143	Actuating variable comparator 2: Input 1	Input	-WC-	[5.1] DPT_Scaling	1 byte
144	Actuating variable comparator 2: Input 2	Input	-WC-	[5.1] DPT_Scaling	1 byte
145	Actuating variable comparator 2: Input 3	Input	-WC-	[5.1] DPT_Scaling	1 byte
146	Actuating variable comparator 2: Input 4	Input	-WC-	[5.1] DPT_Scaling	1 byte
147	Actuating variable comparator 2: Input 5	Input	-WC-	[5.1] DPT_Scaling	1 byte
148	Actuating variable comparator 2: Output	Output	R-CT	[5.1] DPT_Scaling	1 byte
149	Actuating variable comparator 2: Block (1: block)	Output	-WC-	[1.2] DPT_Bool	1 bit
150	Logic input 1	Input	-WC-	[1.2] DPT_Bool	1 bit
151	Logic input 2	Input	-WC-	[1.2] DPT_Bool	1 bit
152	Logic input 3	Input	-WC-	[1.2] DPT_Bool	1 bit
153	Logic input 4	Input	-WC-	[1.2] DPT_Bool	1 bit
154	Logic input 5	Input	-WC-	[1.2] DPT_Bool	1 bit
155	Logic input 6	Input	-WC-	[1.2] DPT_Bool	1 bit
156	Logic input 7	Input	-WC-	[1.2] DPT_Bool	1 bit
157	Logic input 8	Input	-WC-	[1.2] DPT_Bool	1 bit
158	Logic input 9	Input	-WC-	[1.2] DPT_Bool	1 bit
159	Logic input 10	Input	-WC-	[1.2] DPT_Bool	1 bit
160	Logic input 11	Input	-WC-	[1.2] DPT_Bool	1 bit
161	Logic input 12	Input	-WC-	[1.2] DPT_Bool	1 bit
162	Logic input 13	Input	-WC-	[1.2] DPT_Bool	1 bit
163	Logic input 14	Input	-WC-	[1.2] DPT_Bool	1 bit
164	Logic input 15	Input	-WC-	[1.2] DPT_Bool	1 bit
165	Logic input 16	Input	-WC-	[1.2] DPT_Bool	1 bit
166	AND logic 1: 1-bit switching output	Output	R-CT	[1.2] DPT_Bool	1 bit
167	AND logic 1: 8-bit output A	Output	R-CT	[5.*]	1 byte
168	AND logic 1: 8-bit output B	Output	R-CT	[5.*]	1 byte
169	AND logic 1: Block	Input	-WC-	[1.1] DPT_Switch	1 bit

No.	Text	Function	Flags	DPT type	Size
170	AND logic 2: 1-bit switching output	Output	R-CT	[1.2] DPT_Bool	1 bit
171	AND logic 2: 8-bit output A	Output	R-CT	[5.*]	1 byte
172	AND logic 2: 8-bit output B	Output	R-CT	[5.*]	1 byte
173	AND logic 2: Block	Input	-WC-	[1.1] DPT_Switch	1 bit
174	AND logic 3: 1-bit switching output	Output	R-CT	[1.2] DPT_Bool	1 bit
175	AND logic 3: 8-bit output A	Output	R-CT	[5.*]	1 byte
176	AND logic 3: 8-bit output B	Output	R-CT	[5.*]	1 byte
177	AND logic 3: Block	Input	-WC-	[1.1] DPT_Switch	1 bit
178	AND logic 4: 1-bit switching output	Output	R-CT	[1.2] DPT_Bool	1 bit
179	AND logic 4: 8-bit output A	Output	R-CT	[5.*]	1 byte
180	AND logic 4: 8-bit output B	Output	R-CT	[5.*]	1 byte
181	AND logic 4: Block	Input	-WC-	[1.1] DPT_Switch	1 bit
182	OR logic 1: 1-bit switching output	Output	R-CT	[1.2] DPT_Bool	1 bit
183	OR logic 1: 8-bit output A	Output	R-CT	[5.*]	1 byte
184	OR logic 1: 8-bit output B	Output	R-CT	[5.*]	1 byte
185	OR logic 1: Block	Input	-WC-	[1.1] DPT_Switch	1 bit
186	OR logic 2: 1-bit switching output	Output	R-CT	[1.2] DPT_Bool	1 bit
187	OR logic 2: 8-bit output A	Output	R-CT	[5.*]	1 byte
188	OR logic 2: 8-bit output B	Output	R-CT	[5.*]	1 byte
189	OR logic 2: Block	Input	-WC-	[1.1] DPT_Switch	1 bit
190	OR logic 3: 1-bit switching output	Output	R-CT	[1.2] DPT_Bool	1 bit
191	OR logic 3: 8-bit output A	Output	R-CT	[5.*]	1 byte
192	OR logic 3: 8-bit output B	Output	R-CT	[5.*]	1 byte
193	OR logic 3: Block	Input	-WC-	[1.1] DPT_Switch	1 bit
194	OR logic 4: 1-bit switching output	Output	R-CT	[1.2] DPT_Bool	1 bit
195	OR logic 4: 8-bit output A	Output	R-CT	[5.*]	1 byte
196	OR logic 4: 8-bit output B	Output	R-CT	[5.*]	1 byte
197	OR logic 4: Block	Input	-WC-	[1.1] DPT_Switch	1 bit
198	Pushbutton 1 (hold)	Output	R-CT	[1.8] DPT_UpDown	1 bit
199	Pushbutton 1 (tap)	Output	R-CT	[1.10] DPT_Start	1 bit
200	Pushbutton 1 switching	Output	R-CT	[1.1] DPT_Switch	1 bit
201	Pushbutton 1 dimming	Input / Output	RWCT	[3.7] DPT_Control_Dimming	4 bit
202	Pushbutton 1 encoder 8 bit	Output	R-CT	[5.10] DPT_Value_1_Ucount	1 byte

No.	Text	Function	Flags	DPT type	Size
203	Pushbutton 1 encoder 16 bit	Output	R-CT	[9] 9.xxx	2 bytes
204	Pushbutton 1 Scene (call up)	Output	R-CT	[18.1] DPT_Scene-Control	1 byte
205	Pushbutton 2 (hold)	Output	R-CT	[1.8] DPT_UpDown	1 bit
206	Pushbutton 2 (tap)	Output	R-CT	[1.10] DPT_Start	1 bit
207	Pushbutton 2 switching	Output	R-CT	[1.1] DPT_Switch	1 bit
208	Pushbutton 2 dimming	Input / Output	RWCT	[3.7] DPT_Control_Dimming	4 bit
209	Pushbutton 2 encoder 8 bit	Output	R-CT	[5.10] DPT_Value_1_Ucount	1 byte
210	Pushbutton 2 encoder 16 bit	Output	R-CT	[9] 9.xxx	2 bytes
211	Pushbutton 2 Scene (call up)	Output	R-CT	[18.1] DPT_Scene-Control	1 byte
212	Pushbutton 3 (hold)	Output	R-CT	[1.8] DPT_UpDown	1 bit
213	Pushbutton 3 (tap)	Output	R-CT	[1.10] DPT_Start	1 bit
214	Pushbutton 3 switching	Output	R-CT	[1.1] DPT_Switch	1 bit
215	Pushbutton 3 dimming	Input / Output	RWCT	[3.7] DPT_Control_Dimming	4 bit
216	Pushbutton 3 encoder 8 bit	Output	R-CT	[5.10] DPT_Value_1_Ucount	1 byte
217	Pushbutton 3 encoder 16 bit	Output	R-CT	[9] 9.xxx	2 bytes
218	Pushbutton 3 Scene (call up)	Output	R-CT	[18.1] DPT_Scene-Control	1 byte
219	Pushbutton 4 (hold)	Output	R-CT	[1.8] DPT_UpDown	1 bit
220	Pushbutton 4 (tap)	Output	R-CT	[1.10] DPT_Start	1 bit
221	Pushbutton 4 switching	Output	R-CT	[1.1] DPT_Switch	1 bit
222	Pushbutton 4 dimming	Input / Output	RWCT	[3.7] DPT_Control_Dimming	4 bit
223	Pushbutton 4 encoder 8 bit	Output	R-CT	[5.10] DPT_Value_1_Ucount	1 byte
224	Pushbutton 4 encoder 16 bit	Output	R-CT	[9] 9.xxx	2 bytes
225	Pushbutton 4 Scene (call up)	Output	R-CT	[18.1] DPT_Scene-Control	1 byte
226	Pushbutton 5 (hold)	Output	R-CT	[1.8] DPT_UpDown	1 bit
227	Pushbutton 5 (tap)	Output	R-CT	[1.10] DPT_Start	1 bit
228	Pushbutton 5 switching	Output	R-CT	[1.1] DPT_Switch	1 bit
229	Pushbutton 5 dimming	Input / Output	RWCT	[3.7] DPT_Control_Dimming	4 bit
230	Pushbutton 5 encoder 8 bit	Output	R-CT	[5.10] DPT_Value_1_Ucount	1 byte
231	Pushbutton 5 encoder 16 bit	Output	R-CT	[9] 9.xxx	2 bytes
232	Pushbutton 5 Scene (call up)	Output	R-CT	[18.1] DPT_Scene-Control	1 byte

No.	Text	Function	Flags	DPT type	Size
233	Pushbutton 6 (hold)	Output	R-CT	[1.8] DPT_UpDown	1 bit
234	Pushbutton 6 (tap)	Output	R-CT	[1.10] DPT_Start	1 bit
235	Pushbutton 6 switching	Output	R-CT	[1.1] DPT_Switch	1 bit
236	Pushbutton 6 dimming	Input / Output	RWCT	[3.7] DPT_Control_Dimming	4 bit
237	Pushbutton 6 encoder 8 bit	Output	R-CT	[5.10] DPT_Value_1_Ucount	1 byte
238	Pushbutton 6 encoder 16 bit	Output	R-CT	[9] 9.xxx	2 bytes
239	Pushbutton 6 Scene (call up)	Output	R-CT	[18.1] DPT_Scene-Control	1 byte
240	Pushbutton 7 (hold)	Output	R-CT	[1.8] DPT_UpDown	1 bit
241	Pushbutton 7 (tap)	Output	R-CT	[1.10] DPT_Start	1 bit
242	Pushbutton 7 switching	Output	R-CT	[1.1] DPT_Switch	1 bit
243	Pushbutton 7 dimming	Input / Output	RWCT	[3.7] DPT_Control_Dimming	4 bit
244	Pushbutton 7 encoder 8 bit	Output	R-CT	[5.10] DPT_Value_1_Ucount	1 byte
245	Pushbutton 7 encoder 16 bit	Output	R-CT	[9] 9.xxx	2 bytes
246	Pushbutton 7 Scene (call up)	Output	R-CT	[18.1] DPT_Scene-Control	1 byte
247	Pushbutton 8 (hold)	Output	R-CT	[1.8] DPT_UpDown	1 bit
248	Pushbutton 8 (tap)	Output	R-CT	[1.10] DPT_Start	1 bit
249	Pushbutton 8 switching	Output	R-CT	[1.1] DPT_Switch	1 bit
250	Pushbutton 8 dimming	Input / Output	RWCT	[3.7] DPT_Control_Dimming	4 bit
251	Pushbutton 8 encoder 8 bit	Output	R-CT	[5.10] DPT_Value_1_Ucount	1 byte
252	Pushbutton 8 encoder 16 bit	Output	R-CT	[9] 9.xxx	2 bytes
253	Pushbutton 8 Scene (call up)	Output	R-CT	[18.1] DPT_Scene-Control	1 byte

5. Parameter settings

5.1. Behaviour on power failure/ restoration of power

Behaviour following a failure of the bus power supply:

The device sends nothing.

Behaviour on bus restoration of power and following programming or reset:

The device sends all outputs according to their send behaviour set in the parameters with the delays established in the "General settings" parameter block.

5.2. General settings

Set basic characteristics for the data transfer. A different **transmission delay** prevents an overload of the bus shortly after the reset.

Transmission delay after reset/bus restoration for:	
Readings	<u>5 s</u> • ... • 2 h
Threshold values and switching outputs	<u>5 s</u> • ... • 2 h
Controller objects	<u>5 s</u> • ... • 2 h
Comparator, logic and key objects	<u>5 s</u> • ... • 2 h
Maximum telegram rate	<ul style="list-style-type: none"> • 1 telegram per second • ... • <u>10 telegrams per second</u> • ... • 20 telegrams per second

Indicate the sensors connected to the two **sensor inputs** of the device:

1. Whether a plug and contact sensor T-NTC-ST is connected.

Use plug-in sensor	<u>No</u> • Yes
Use plug-in sensor malfunction object (if the plug-in sensor is used)	<u>No</u> • Yes

2. Whether a circuit board sensor (sensor for wall mounting in junction box) T-UP basic (temperature) or TH-UP basic (temperature and air humidity) is connected.

Type of board sensor	<ul style="list-style-type: none"> • <u>not used</u> • Temperature sensor • Temperature and humidity sensor
Use board sensor malfunction object (if a circuit board sensor is used)	<u>No</u> • Yes

The settings for "temperature plug-in sensor reading" and "temperature circuit board sensor reading" and possibly the settings for air humidity (reading, threshold values,

controls, dew point, comfort field) are only shown in the following if a sensor input has been activated.

5.3. Temperature readings

The settings for "temperature plug-in sensor reading" and "temperature circuit board sensor reading" are only shown if the respective sensor input has been activated in the "General settings". The setting options for both readings are identical.

Use **Offsets** to adjust the readings to be sent.

Offset in 0.1°C	-50...50; <u>0</u>
-----------------	--------------------

The unit can calculate a mixed value from its own reading and an external value. Set the **mixed value calculation** if desired.

Use external reading	<u>No</u> • Yes
Ext. Measured value portion of the total reading	5% • 10% • ... • <u>50%</u> • ... • 100%

If an external portion is used, all of the following settings are related to the overall reading!

Set the **send pattern** for the reading.

Send pattern	<ul style="list-style-type: none"> • <u>not</u> • periodically • on change • on change and periodically
On change of (if sent on change)	0.1°C • ... • <u>0.5°C</u> • ... • 5.0°C
Send cycle (if sent periodically)	5 s • <u>10 s</u> • ... • 2 h

The **minimum and maximum readings** can be saved and sent to the bus. Using the "Reset reading min/max." objects the values can be reset to the current readings.

Use minimum and maximum value	<u>No</u> • Yes
-------------------------------	-----------------

The values are not retained after a reset.

5.4. Temperature threshold values

The **Interface KNX B8-TH** provides eight threshold values for the temperature measurement of the sensors connected to the device.

Use threshold values 1/2/3/4/5/6/7/8	<u>No</u> • Yes
--------------------------------------	-----------------

5.4.1. Threshold values 1...8

Threshold value

First decide to which of the sensors connected to the device the threshold value is to be valid for.

Threshold value valid for reading of	<u>Plug-in sensor</u> • circuit board sensor
--------------------------------------	--

Decide in which cases **threshold values and delay times** received are to be kept per object. The parameter is only taken into consideration if the setting by object is activated further down. Please note that the setting "After power restoration and programming" should not be used for the initial start-up, as the factory settings are always used until the first call (setting via objects is ignored).

The threshold values and delays received by the communication object	
are	<ul style="list-style-type: none"> • <u>not</u> • to be retained after power restoration • to be retained after power restoration and programming
.	

Set the threshold values directly in the application program using parameters, or define them via the bus using a communications object.

Threshold value setpoint using parameter:

Set the threshold values and hysteresis directly.

Threshold value setpoint using	Parameter • Communication objects
Threshold value in 0.1°C	-300 ... 800; <u>200</u>
Hysteresis of the threshold value in %	0 ... 50; <u>20</u>

Threshold value setpoint using a communication object:

Beforehand, enter how the threshold value will be received from the bus. Basically, a new value can be received, or simply a command to increase or decrease.

During initial commissioning, a threshold value must be defined which will be valid until the first call with a new threshold value. For units which have already been taken into service, the last communicated threshold value can be used. Basically, a temperature range is given in which the threshold value can be changed (object value limit).

A set threshold value will be retained until a new value or a change is transferred. The current value is saved in so that it is retained in the event of a power supply failure and will be available again once the power supply is restored.

Threshold value setpoint using	Parameter • Communication objects
Start threshold value in 0.1°C valid until first call	-300 ... 800; <u>200</u>
Object value limit (min) in 0.1°C	<u>-300</u> ...800

Object value limit (max) in 0.1°C	-300... <u>800</u>
Type of threshold change	<u>Absolute value</u> • Increase/decrease
Step size (upon increase/decrease change)	<u>0.1°C</u> • ... • 5°C

Set the **hysteresis** independently of the type of threshold value setting.

Hysteresis setting	in % • <u>absolute</u>
Hysteresis in 0.1°	0...1100; <u>50</u>
Hysteresis in % of the threshold value	0 ... 50; <u>20</u>

Switching output

Set the behaviour of the switching output when a threshold value is exceeded/undercut. The output switching delay can be set using objects or directly as a parameter.

When the following conditions apply, the output is (TV = Threshold value)	<ul style="list-style-type: none"> • <u>TV above = 1</u> TV - Hyst. below = 0 • TV above = 0 TV - Hyst. below = 1 • TV below = 1 TV + hysteresis above = 0 • TV below = 0 TV + hysteresis above = 1
Delays can be set via objects (in seconds)	<u>No</u> • Yes
Switching delay from 0 to 1 (if delay is adjustable via objects: valid until 1st communication)	<u>None</u> • 1 s • 2 s • 5 s • 10 s • ... • 2 h
Switching delay from 1 to 0 (if delay is adjustable via objects: valid until 1st communication)	<u>None</u> • 1 s • 2 s • 5 s • 10 s • ... • 2 h
Switching output sends	<ul style="list-style-type: none"> • <u>on change</u> • on change to 1 • on change to 0 • on change and periodically • on change to 1 and periodically • on change to 0 and periodically
Cycle (is only sent if periodically is selected)	<u>5 sec</u> • 10 sec • 30 sec... • 2 hrs

Blocking

The switching output can be blocked using an object.

Use switching output block	<u>No</u> • Yes
Analysis of the blocking object	<ul style="list-style-type: none"> • <u>At value 1: block</u> At value 0: release • At value 0: block At value 1: release
Blocking object value before first call	<u>0</u> • 1

Set the **output behaviour during and after blocking** .

Behaviour of the switching output	
On block	<ul style="list-style-type: none"> • <u>Do not send message</u> • send 0 • send 1
On release (with 2 seconds release delay)	[Dependent on the "Switching output sends" setting]

The behaviour of the switching output on release is dependent on the value of the parameter "Switching output sends" (see "Switching output")

Switching output sends on change	<ul style="list-style-type: none"> • Do not send message • Send switching output status
Switching output sends on change to 1	<ul style="list-style-type: none"> • Do not send message • if switching output = 1 → send 1
Switching output sends on change to 0	<ul style="list-style-type: none"> • Do not send message • if switching output = 0 → send 0
Switching output sends on change and periodically	Send switching output status
Switching output sends on change to 1 and periodically	if switching output = 1 → send 1
Switching output sends on change to 0 and periodically	if switching output = 0 → send 0

5.5. Temperature PI controller

Activate the controller

Use controller	<u>No</u> • Yes
----------------	-----------------

Decide whether the controller is to use the reading of the plug-in or circuit board sensor connected to the device.

Rule applies to	<u>Plug-in sensor</u> • circuit board sensor
-----------------	--

General rules

Decide in which cases **nominal values and delay times** received per object are to be kept. The parameter is only taken into consideration if the setting by object is activated further down. Please note that the setting "After power restoration and programming" should not be used for the initial start-up, as the factory settings are always used until the first call (setting via objects is ignored).

The nominal values and delay times received by the communication object are	<ul style="list-style-type: none"> • not to be maintained • <u>after power restoration</u> • after power restoration and programming
.	

For an adequate regulation of the indoor temperature, comfort, standby, eco and building protection modes may be used.

Comfort when present,

Standby when absent,

Eco as a night-time mode and

Frost / heat protection (building protection) e.g. when the window is open.

The settings for the temperature control include the set point temperatures for the individual modes. Objects are used to determine which mode is to be selected. A change of mode may be triggered manually or automatically (e.g. by a timer, window contact).

The **mode** may be switched with **two 8 bit objects** of different priority. Objects

„... HVAC mode (Prio 2)“ for switching in everyday operation and

„... HVAC mode (Prio 1)“ for central switching with higher priority.

The objects are coded as follows:

0 = Auto

1 = Comfort

2 = Standby

3 = Eco

4 = Building protection

Alternatively, you can use **three objects**, with one object switching between eco and standby mode and the two others are used to activate comfort mode or frost/heat protection mode. The comfort object then blocks the eco/standby object, and frost/heat protection objects have the highest priority. Objects

„... Mode (1: Eco, 0: Standby)“,

„... comfort activation mode“ and

„... frost/heat protection activation mode“

Switch mode via	<ul style="list-style-type: none"> • two 8-bit objects (HVAC modes) • three 1-bit objects
-----------------	---

Select the **mode to be activated after reset** (e.g. power failure, reset of the line via the bus). (Default).

Then configure a temperature control **block** by the blocking object.

Mode after reset	<ul style="list-style-type: none"> • Comfort • <u>Standby</u> • Eco • Building protection
Behaviour of the blocking object with value	<ul style="list-style-type: none"> • <u>1 = Block 0 = release</u> • 0 = block 1 = release
Value of the blocking object after reset	<u>0</u> • 1

Specify when the current **control variables** are to be **sent** to the bus. Periodic transmission is safer if a message does not reach a recipient. You may also set up periodical monitoring by the actuator with this setting.

Transmit control variable	<ul style="list-style-type: none"> • <u>on change</u> • on change and periodically
from change of (in % absolute)	1...10; <u>2</u>

Cycle <i>(if sent periodically)</i>	5 s • ... • <u>5 min</u> • ... • 2 h
--	--------------------------------------

The **status object** reports the current status of the output (0 = OFF, 0 = ON) and may for example be used for visualisation, or to switch off the heating pump as soon as the heating is switched off.

Send status objects	<ul style="list-style-type: none"> • <u>on change</u> • on change to 1 • on change to 0 • on change and periodically • on change to 1 and periodically • on change to 0 and periodically
Cycle <i>(if sent periodically)</i>	5 s • ... • <u>5 min</u> • ... • 2 h

Then define the **type of setting**. Heating and/or cooling may be controlled in two stages.

Type of control	<ul style="list-style-type: none"> • <u>Single stage heating</u> • Dual-stage heating • Single-stage cooling • Dual-stage cooling • Single-stage heating + single-stage cooling • Dual-stage heating + single-stage cooling • Dual-stage heating + dual-stage cooling
-----------------	--

General set point values

You may enter separate set point values for each mode or use the comfort set point as a basic value.

If you are using the controls for both heating *and* cooling, you may also select the setting "separately with switching object". Systems used for cooling in the summer and for heating in the winter can thus be switched from one to the other.

If you are using the basic value, only the deviation from the comfort set point value is listed for the other modes (e. g., 2°C less for standby mode).

Setting the nominal values <i>(if only heating or only cooling is used)</i>	<ul style="list-style-type: none"> • <u>separately</u> • with comfort set point as a basis
Setting the nominal values <i>(only if both heating and cooling are used)</i>	<ul style="list-style-type: none"> • <u>with separate nominal values with switching object</u> • with separate nominal values without switching object • with comfort set point as a basis with switching object • with comfort set point as a basis without switching object

Behaviour of the switching object at value (if heating and cooling takes place via switching object)	<ul style="list-style-type: none"> • <u>0</u> = Heating 1 = Cooling • 1 = Heating <u>0</u> = Cooling
Value of the switching object after reset (if heating and cooling takes place via switching object)	<u>0</u> • 1

The **increment** for the setpoint changes is predefined. Whether the change only remains temporarily active (not saved) or is also retained after power supply restoration (and programming), is specified in the first section of "General control". This also applies to a comfort extension.

Increment for setpoint changes (in 0.1 °C)	1... 50; <u>10</u>
---	--------------------

The control may be reset to comfort mode from eco mode, which is used as night mode, via the comfort extension. This allows the user to maintain the comfort setpoint value for a longer time, e.g. when having guests. The duration of this comfort extension period is set. After the comfort extension period expires, the system returns to eco mode.

Comfort extension time in seconds (can only be activated from eco mode)	1...36000; <u>3600</u>
--	------------------------

Comfort Setpoint

Comfort mode is usually used for daytime mode when people are present. A starting value is defined for the comfort setpoint as well as a temperature range in which the setpoint value may be modified.

Starting heating/cooling setpoint (in 0.1 °C) valid until 1st communication (not upon saving the setpoint value after programming)	-300...800; <u>210</u>
--	------------------------

If setpoint values are entered separately:

Min. object value heating/cooling (in 0.1 °C)	-300...800; <u>160</u>
Max. object value heating/cooling (in 0.1 °C)	-300...800; <u>280</u>

If the comfort setpoint value is used as a basis:

If the comfort setpoint value is used as a basis, the reduction/increment of the value is set.

Minimum base setpoint (in 0.1°C)	-300...800; <u>160</u>
Maximum base setpoint (in 0.1°C)	-300...800; <u>280</u>
Reduction by up to (in 0.1°C)	0...200; <u>50</u>
Increase by up to (in 0.1°C)	0...200; <u>50</u>

If the comfort setpoint is used as the basis without a switching object, a dead zone is specified for the control mode "heating *and* cooling" to avoid direct switching from heating to cooling.

Dead zone between heating and cooling (only if both heating AND cooling are used)	1...100; <u>50</u>
--	--------------------

Standby setpoint

Standby mode is usually used for daytime mode when people are absent.

If setpoint values are entered separately:

A starting setpoint value is defined as well as a temperature range in which the setpoint value may be changed.

Starting heating/cooling setpoint (in 0.1 °C) valid until 1st communication	-300...800; <u>210</u>
Min. object value heating/cooling (in 0.1 °C)	-300...800; <u>160</u>
Max. object value heating/cooling (in 0.1 °C)	-300...800; <u>280</u>

If the comfort setpoint value is used as a basis:

If the comfort setpoint value is used as a basis, the reduction/increment of the value is set.

Reduce heating setpoint (in 0.1°C) (for heating)	0...200; <u>30</u>
Increase cooling setpoint (in 0.1°C) (for cooling)	0...200; <u>30</u>

Eco setpoint

Eco mode is usually used for night mode.

If setpoint values are entered separately:

A starting setpoint value is defined as well as a temperature range in which the setpoint value may be changed.

Starting heating/cooling setpoint (in 0.1 °C) valid until 1st communication	-300...800; <u>210</u>
Min. object value heating/cooling (in 0.1 °C)	-300...800; <u>160</u>
Max. object value heating/cooling (in 0.1 °C)	-300...800; <u>280</u>

If the comfort setpoint value is used as a basis:

If the comfort setpoint value is used as a basis, the reduction/increment of the value is set.

Reduce heating setpoint (in 0.1°C) (for heating)	0...200; <u>50</u>
Increase cooling setpoint (in 0.1°C) (for cooling)	0...200; <u>60</u>

Setpoint values for frost/heat protection (building protection)

The building protection mode is for example used as long as windows are opened for ventilation. Setpoints for frost protection (heating) and heat protection (cooling) are determined which may not be modified from outside (no access via operating devices etc.). The building protection mode may be activated with delay, which allows you to leave the building before the controls switch to frost/heat protection mode.

Setpoint frost protection (in 0.1°C)	-300...800; <u>70</u>
Activation delay	less than • 5 s • ... • <u>5 min</u> • ... • 2 h
Setpoint heat protection (in 0.1°C)	-300...800; <u>350</u>
Activation delay	less than • 5 s • ... • <u>5 min</u> • ... • 2 h

General control variables

This setting appears for the control types "Heating *and* Cooling" only. Here, you can decide whether to use a common control variable for heating and cooling. If the 2nd level has a common control variable, you also determine the control mode of the 2nd level here.

For heating and cooling	<ul style="list-style-type: none"> • <u>separate control variables are used</u> • common control variables are used for Level 1 • common control variables are used for Level 2 • common control variable are used for Level 1+2
Use control variable for 4/6-way valve (only for common control variables in level 1)	<u>No</u> • Yes
Control type (for level 2 only)	<ul style="list-style-type: none"> • 2-point-control • PI control
Control variable of the 2nd Level is on (only for level 2 with 2 point controlling)	<ul style="list-style-type: none"> • <u>1 bit object</u> • 8 bit object

When using the control variable for a 4/6 way valve, the following applies:

0%...100% heating = 66%...100% control variable

OFF = 50% control variable

0%...100% cooling = 33%...0% control variable

5.5.1. Heating control level 1/2

If a heating control mode is configured, one or two setting sections for the heating levels are displayed.

In the 1st level, heating is controlled by a PI control, which allows to either enter control parameters or select predetermined applications.

In the 2nd level (therefore only in case of 2-level heating), heating is controlled via a PI or a 2-point-control.

In level 2, the setpoint difference between the two levels must also be specified, i.e. below which setpoint deviation the second level is added.

Setpoint difference between 1st and 2nd level (in 0.1°C) <i>(for level 2)</i>	0...100; <u>40</u>
Control type <i>(for level 2, no common control variables)</i>	<ul style="list-style-type: none"> • 2-point-control • PI control
Control variable is a <i>(for level 2 with 2-point controlling, no common control variables)</i>	<ul style="list-style-type: none"> • <u>1 bit object</u> • 8 bit object

PI control with control parameters:

This setting allows individual input of the parameters for PI control.

Control type	• PI control
Setting of the controller by	<ul style="list-style-type: none"> • Controller parameter • specified applications

Specify the deviation from the setpoint value at which the maximum control variable value is reached, i.e. the point at which maximum heating power is activated.

The reset time shows how quickly the controller responds to deviations from the setpoint value. In case of a short reset time, the control responds with a fast increase of the control variable. In case of a long reset time, the control responds somewhat less urgently and needs longer until the necessary control variable for the setpoint value deviation is reached.

You should set the time appropriate to the heating system at this point (observe manufacturer's instructions).

Maximum control variable is reached at setpoint/actual difference of (in °C)	0... <u>5</u>
Reset time (in min.)	1...255; <u>30</u>

Now specify what should be sent when the control is blocked. Set a value greater 0 (=OFF) to receive a basic heating level, e.g. for floor heating.

On release, the control variable follows the rule again.

When blocked, the control variable shall	<ul style="list-style-type: none"> • <u>not be sent</u> • send a specific value
Value (in %) <i>(if a value is sent)</i>	<u>0</u> ...100

In case of a common control variable for heating and cooling, 0 is always transmitted as a fixed value.

PI control with predetermined application:

This setting provides fixed parameters for frequent applications.

Control type	<ul style="list-style-type: none"> • PI control
Setting of the controller by	<ul style="list-style-type: none"> • Controller parameter • specified applications
Application	<ul style="list-style-type: none"> • Warm water heating • Floor heating • Convection unit • Electric heating
Maximum control variable is reached at setpoint/actual difference of (in °C)	Warm water heating: 5 Floor heating: 5 Convection unit: 4 Electric heating: 4
Reset time (in min.)	Warm water heating: 150 Floor heating: 240 Convection unit: 90 Electric heating: 100

Now specify what should be sent when the control is blocked. Set a value greater 0 (=OFF) to receive a basic heating level, e.g. for floor heating.

On release, the control variable follows the rule again.

When blocked, the control variable shall	<ul style="list-style-type: none"> • not be sent • send a specific value
Value (in %) (if a value is sent)	<u>0</u> ...100

In case of a common control variable for heating and cooling, 0 is always transmitted as a fixed value.

2-point-control (only level 2):

2-point-control is used for systems which are only set to ON or OFF.

Control type (is determined at a higher level for common control variables)	<ul style="list-style-type: none"> • 2-point-control
--	--

Enter the hysteresis that prevents frequent on/off switching of temperatures in the threshold range.

Hysteresis (in 0.1°C)	0...100; <u>20</u>
-----------------------	--------------------

If separate control variables are used, select whether the control variable of the 2nd level is a 1 bit object (on/off) or an 8 bit object (on with percentage/off).

Control variable is a	<ul style="list-style-type: none"> • <u>1 bit object</u> • 8 bit object
Value (in %) <i>(for 8 bit object)</i>	<u>0...100</u>

Now specify what should be sent when the control is blocked. Set a value greater 0 (=OFF) to receive a basic heating level, e.g. for floor heating. On release, the control variable follows the rule again.

When blocked, the control variable shall	<ul style="list-style-type: none"> • not be sent • send a specific value
Value (in %) <i>only if a value is sent</i>	<u>0...100</u>

5.5.2. Cooling control level 1/2

If a cooling control mode is configured, one or two setting sections for the cooling levels are displayed.

In the 1st level, cooling is controlled by a PI control in which either control parameters can be entered or predetermined applications can be selected.

In the 2nd level (therefore only for 2-level cooling), cooling is controlled via a PI or a 2-point-control.

In level 2, the setpoint deviation between the two levels must also be specified, i.e. above which setpoint value deviation the second level is added.

Setpoint difference between 1st and 2nd level (in 0.1°C) <i>(for level 2)</i>	<u>0...100; 40</u>
Control type <i>(for level 2, no common control variables)</i>	<ul style="list-style-type: none"> • 2-point-control • PI control
Control variable is a <i>(for level 2 with 2-point controlling, no common control variables)</i>	<ul style="list-style-type: none"> • <u>1 bit object</u> • 8 bit object

PI control with control parameters:

This setting allows individual input of the parameters for PI control.

Control type	<ul style="list-style-type: none"> • PI control
Setting of the controller by	<ul style="list-style-type: none"> • Controller parameter • specified applications

Specify the deviation from the setpoint value which reaches maximum variable value, i.e. the point at which maximum cooling power is activated.

The reset time shows how quickly the controller responds to deviations from the setpoint value. In case of a short reset time, the control responds with a fast increase of the control variable. In case of a long reset time, the control responds somewhat less

urgently and needs longer until the necessary control variable for the setpoint value deviation is reached. You should set the time appropriate to the cooling system at this point (observe manufacturer's instructions).

Maximum control variable is reached at setpoint/actual difference of (in °C)	0... <u>5</u>
Reset time (in min.)	1...255; <u>30</u>

Now specify what should be sent when the control is blocked.
On release, the control variable follows the rule again.

When blocked, the control variable shall	<ul style="list-style-type: none"> • <u>not be sent</u> • send a specific value
Value (in %) (if a value is sent)	<u>0</u> ...100

In case of a common control variable for heating and cooling, 0 is always transmitted as a fixed value.

PI control with predetermined application:

This setting provides fixed parameters for a cooling ceiling

Control type	• PI control
Setting of the controller by	<ul style="list-style-type: none"> • Controller parameter • specified applications
Application	• Cooling ceiling
Maximum control variable is reached at setpoint/actual difference of (in °C)	Cooling ceiling: 5
Reset time (in min.)	Cooling ceiling: 30

Now specify what should be sent when the control is blocked.
On release, the control variable follows the rule again.

When blocked, the control variable shall	<ul style="list-style-type: none"> • not be sent • send a specific value
Value (in %) (if a value is sent)	<u>0</u> ...100

2-point-control (only level 2):

2-point-control is used for systems which are only set to ON or OFF.

Control type <i>is determined at a higher level for common variables</i>	• 2-point-control
---	--------------------------

Enter the hysteresis that prevents frequent on/off switching of temperatures in the threshold range.

Hysteresis (in 0.1°C)	0...100; <u>20</u>
-----------------------	--------------------

If separate control variables are used, select whether the control variable of the 2nd level is a 1 bit object (on/off) or an 8 bit object (on with percentage/off).

Control variable is a	<ul style="list-style-type: none"> • <u>1 bit object</u> • 8 bit object
Value (in %) (for 8 bit object)	0... <u>100</u>

Now specify what should be sent when the control is blocked.
On release, the control variable follows the rule again.

When blocked, the control variable shall	<ul style="list-style-type: none"> • <u>not be sent</u> • send a specific value
Value (in %) (if a value is sent)	<u>0</u> ...100

In case of a common control variable for heating and cooling, 0 is always transmitted as a fixed value.

5.6. Humidity reading

The settings for the "humidity reading" and other air humidity settings are only shown if the circuit board sensor input has been set to "temperature and humidity sensor" in the "General settings".

Use **Offsets** to adjust the readings to be sent.

Offset in 0.1% RH increments	-100...100; <u>0</u>
------------------------------	----------------------

The unit can calculate a mixed value from its own reading and an external value. Set the **mixed value calculation** if desired.

Use external reading	<u>No</u> • Yes
Ext. Measured value portion of the total reading	5% • 10% • ... • <u>50%</u> • ... • 100%

If an external portion is used, all of the following settings are related to the overall reading!

Set the **send pattern** for the reading.

Send pattern	<ul style="list-style-type: none"> • <u>not</u> • periodically • on change • on change and periodically
On change of (if sent on change)	0.1% RH • ... • <u>1.0% RH</u> • ... • 20.0% RH
Send cycle (if sent periodically)	5 s • <u>10 s</u> • ... • 2 h

The **minimum and maximum readings** can be saved and sent to the bus. Using the "Reset reading min/max." objects the values can be reset to the current readings.

Use minimum and maximum value	<u>No</u> • Yes
-------------------------------	-----------------

The values are not retained after a reset.

5.7. Humidity threshold values

The settings for the "humidity threshold values" and other air humidity settings are only shown if the circuit board sensor input has been set to "temperature and humidity sensor" in the "General settings".

The **Interface KNX B8-TH** provides two threshold values for the humidity measurement of the sensors connected to the device.

Use threshold value 1/2	<u>No</u> • Yes
-------------------------	-----------------

5.7.1. Threshold value 1/2

Threshold value

Set, in which cases **threshold values and delay times** received via objects are to be retained. The parameter is only taken into consideration if the setting via object is activated below. Please note that the setting "After power supply restoration and programming" should not be used for the initial start-up, as the factory settings are always used until the first communication (setting via objects is ignored).

Maintain the	
threshold values and delays received via communication objects	<ul style="list-style-type: none"> • <u>never</u> • after power supply restoration • after power supply restoration and programming

Set the threshold value directly in the application program using parameters, or define them via the bus using a communication object.

Threshold value setting using parameter:

Set the threshold values and hysteresis directly.

Threshold value setting using	Parameter • Communication objects
Threshold value in 0.1% RH	1 ... 1000; <u>650</u>

Threshold value setting using a communication object:

Define, how the threshold value is to be received from the bus. Basically, a new value can be received, or simply a command to increase or decrease.

During initial commissioning, a threshold value must be defined, which will be valid until the first communication with a new threshold value. For units which have already

been taken into service, the last communicated threshold value can be used. Basically, a humidity range is specified in which the threshold value can be changed (object value limit).

A set threshold value will be retained until a new value or a change is transferred. The current value is saved, so that it is retained in the event of a power supply failure and will be available once the power supply is restored.

Threshold value setting using	Parameter • Communication objects
Starting threshold value in 0.1% RH valid until first communication	1 ... 1000; <u>650</u>
Object value limit (min.) in 0.1%RH	<u>1</u> ... 1000
Object value limit (max.) in 0.1%RH	1... <u>1000</u>
Type of threshold value change	<u>Absolute value</u> • Increase/decrease
Increment (upon increase/decrease change)	0.1% RH • ... • <u>2.0% RH</u> • ... • 20.0% RH

Set the **hysteresis** independent of the type of threshold value specification.

Hysteresis setting	in % • <u>absolute</u>
Hysteresis in 0.1% RH	0...1000; <u>100</u>
Hysteresis in % (relative to the threshold value)	0 ... 50; <u>20</u>

Switching output

Set the behaviour of the switching output when a threshold value is exceeded/undercut. The output switching delay can be set using objects or directly as a parameter.

When the following conditions apply, the output is (TV = Threshold value)	<ul style="list-style-type: none"> • <u>TV above = 1 TV - hyst. below = 0</u> • <u>TV above = 0 TV - hyst. below = 1</u> • <u>TV below = 1 TV + hyst. above = 0</u> • <u>TV below = 0 TV + hyst. above = 1</u>
Delays can be set via objects (in seconds)	<u>No</u> • Yes
Switching delay from 0 to 1 (If delay can be set via objects: valid until 1st communication)	<u>None</u> • 1 s • 2 s • 5 s • 10 s • ... • 2 h
Switching delay from 1 to 0 (If delay can be set via objects: valid until 1st communication)	<u>None</u> • 1 s • 2 s • 5 s • 10 s • ... • 2 h
Switching output sends	<ul style="list-style-type: none"> • <u>on change</u> • on change to 1 • on change to 0 • on change and periodically • on change to 1 and periodically • on change to 0 and periodically
Cycle (is only sent if periodically is selected)	<u>5 s</u> • 10 s • 30 s... • 2 h

Block

The switching output can be blocked using an object.

Use switching output block	<u>No</u> • Yes
Analysis of the blocking object	<ul style="list-style-type: none"> • <u>At value 1: block</u> At value 0: release • At value 0: block At value 1: release
Blocking object value before first communication	<u>0</u> • 1

Set the **output behaviour during and after blocking**.

Behaviour of the switching output	
On block	<ul style="list-style-type: none"> • <u>Do not send message</u> • send 0 • send 1
On release (with 2 seconds release delay)	[Dependent on the "Switching output sends" setting]

The behaviour of the switching output on release is dependent on the value of the parameter "Switching output sends" (see "Switching output")

Switching output sends on change	<ul style="list-style-type: none"> • Do not send message • Send switching output status
Switching output sends on change to 1	<ul style="list-style-type: none"> • Do not send message • if switching output = 1 → send 1
Switching output sends on change to 0	<ul style="list-style-type: none"> • Do not send message • if switching output = 0 → send 0
Switching output sends on change and periodically	Send switching output status
Switching output sends on change to 1 and periodically	if switching output = 1 → send 1
Switching output sends on change to 0 and periodically	if switching output = 0 → send 0

5.8. Humidity PI control

The settings for the "humidity PI control" and other air humidity settings are only shown if the circuit board sensor input has been set to "temperature and humidity sensor" in the "General settings".

If you activate humidity control, you can use the following settings to define control type, target values, and humidification and dehumidification.

Use humidity control	<u>No</u> • Yes
----------------------	-----------------

General rules

The **Interface KNX B8-TH** can be used to control one- or two-stage dehumidification or combined humidification/dehumidification.

Type of control	<ul style="list-style-type: none"> • <u>One-stage dehumidification</u> • <u>Two-stage dehumidification</u> • <u>Humidification and dehumidification</u>
-----------------	--

Configure a block for the humidity control using the blocking object.

Behaviour of the blocking object with value	<ul style="list-style-type: none"> • <u>1 = Block 0 = release</u> • <u>0 = block 1 = release</u>
Blocking object value before first call	0 • <u>1</u>

Specify when the current control variables are to be sent to the bus. Periodic transmission is safer if a message does not reach a recipient. You may also set up periodic monitoring using an actuator with this setting.

Transmit control variable	<ul style="list-style-type: none"> • <u>on change</u> • <u>on change and periodically</u>
from change (in % absolute)	1...20; <u>2</u>
Cycle (is only sent if periodically is selected)	5 s • ... • <u>5 min</u> • ... • 2 h

The status object shows the current status of the output variable (0 = OFF, >0 = ON) and can for example be used for visualisation.

Send status object(s)	<ul style="list-style-type: none"> • <u>on change</u> • <u>on change to 1</u> • <u>on change to 0</u> • <u>on change and periodically</u> • <u>on change to 1 and periodically</u> • <u>on change to 0 and periodically</u>
Send cycle (is only sent if "periodically" is selected)	5 s • ... • <u>5 min</u> • ... • 2 h

Controller setpoint

Set, in which cases **setpoint values** received via object are to be retained. Please note that the setting "After power supply restoration and programming" should not be used for the initial start-up, as the factory settings are always used until the first communication (setting via objects is ignored).

Maintain the setpoint value received via communication object	<ul style="list-style-type: none"> • <u>never</u> • <u>after power supply restoration</u> • <u>after power supply restoration and programming</u>

During initial commissioning, a **setpoint value** must be defined which is valid until the first communication of a new setpoint value. For units which have already been taken into service, the last communicated setpoint value can be used. Basically, an air hu-

midity range is specified in which the setpoint value can be changed (**object value limit**).

Enter, how the setpoint value will be received from the bus. Basically, a new value can be received, or simply a command to increase or decrease.

A set setpoint value will be retained until a new value or a change is transferred. The current value is saved, so that it is retained in the event of a power supply failure and will be available once the power supply is restored.

Start setpoint in % valid until first communication <i>(not upon saving the setpoint value after programming)</i>	0 ... 100; <u>50</u>
Object value limit (min.) in %	0...100; <u>30</u>
Object value limit (max.) in %	0...100; <u>70</u>
Type of setpoint value change	<u>Absolute value</u> • Increase/decrease
Increment <i>(upon increase/decrease change)</i>	1% • <u>2%</u> • 3% • 5% • 10%

In "Humidification and dehumidification" control mode, a dead zone is specified so that a direct changeover switching between humidification and dehumidification can be avoided.

Dead zone between humidification and dehumidification in % <i>(only if both humidification and dehumidification are used)</i>	0...50; <u>10</u>
--	-------------------

Humidification starts, when the relative air humidity is lower or equal to the setpoint value - dead zone value.

Dehumidification and/or humidification

Depending on the control mode, settings sections for humidification and dehumidification appear (level 1/2).

For dual-level dehumidification, the setpoint value difference between the two levels must be defined, i.e. the setpoint value which, when exceeded, triggers the switch to the 2nd level.

Target value difference between level 1 and 2 in % <i>(for level 2 only)</i>	0...50; <u>10</u>
---	-------------------

Determine the deviation from the setpoint value at which the maximum variable value is reached, i.e. the point at which maximum output is used.

The reset time shows how quickly the controller responds to deviations from the setpoint value. In case of a short reset time, the control responds with a fast increase of the control variable. In case of a long reset time, the control responds somewhat less

urgently and needs longer until the necessary control variable for the setpoint value deviation is reached.

You should set the time appropriate for the humidification/dehumidification system at this point (note manufacturer instructions).

Maximum control variable is reached at target/actual difference of %	1...50; <u>5</u>
Reset time in minutes	1...255; <u>3</u>

Now specify, what should be sent when the control is blocked.

On release, the control variable follows the rule again.

When blocked, the control variable shall	<ul style="list-style-type: none"> • <u>not be sent</u> • send a specific value
Value in % (if a value is sent)	<u>0</u> ...100

5.9. Dewpoint measurement

The settings for the "dewpoint reading" and other air humidity settings are only shown if the circuit board sensor input has been set to "temperature and humidity sensor" in the "General settings".

The **Interface KNX B8-TH** calculates the dewpoint temperature and outputs the value to the bus.

Set which temperature sensor is to be used for dewpoint calculation. Then set the send pattern.

Dewpoint valid for reading of	<u>Plug-in sensor</u> • circuit board sensor
Send pattern	<ul style="list-style-type: none"> • <u>never</u> • periodically • on change • on change and periodically
On change of (if sent on change)	0.1°C • 0.2°C • <u>0.5°C</u> • 1.0°C • 2.0°C • 5.0°C
Send cycle (if sent periodically)	5 sec • <u>10 sec</u> • 30 sec • 1 min • ... • 2 hrs

Activate monitoring of the coolant temperature if required. The menus for the further setting of the monitoring are then displayed.

Use monitoring of the coolant temperature	<u>No</u> • Yes
---	-----------------

5.9.1. Coolant temperature monitoring

A threshold value can be set for the temperature of the coolant, which is based on the current dewpoint temperature (offset/deviation). The switching output of the coolant temperature monitoring system can provide a warning prior to any build-up of condensation in the system, and/or activate appropriate countermeasures.

Threshold value

Threshold value = dewpoint temperature + offset

Set, in which cases **offset** received via object is to be retained. Please note that the setting "After power supply restoration and programming" should not be used for the initial start-up, as the factory settings are always used until the first communication (setting via objects is ignored).

Maintain the offset received via communication object	<ul style="list-style-type: none"> • <u>never</u> • after power supply restoration • after power supply restoration and programming
.	

During initial commissioning, an **offset** must be defined which is valid until the first communication of a new offset. For units which have already been taken into service, the last communicated offset can be used.

A set offset will be retained until a new value or a change is transferred. The current value is saved, so that it is retained in the event of a power supply failure and will be available once the power supply is restored.

Start offset in °C valid until first communication	0...200; <u>30</u>
Increment for offset change	<u>0.1°C</u> • 0.2°C • 0.3°C • 0.4°C • 0.5°C • 1°C • 2°C • 3°C • 4°C • 5°C
Hysteresis setting	in % • <u>absolute</u>
Hysteresis of the threshold value in % (for setting in %)	0 ... 50; <u>20</u>
Threshold value hysteresis in 0.1°C increments (at absolute setting)	0 ... 1000; <u>50</u>
Threshold value sends	<ul style="list-style-type: none"> • <u>never</u> • periodically • on change • on change and periodically
At and above change of (if sent on change)	<u>0.1°C</u> • 0.2°C • 0.5°C • 1.0°C • 2.0°C • 5.0°C
Send cycle (if sent periodically)	5 s • <u>10 s</u> • 30 s • 1 min • ... • 2 h

Switching output

The output switching delay can be set using objects or directly as a parameter.

When the following conditions apply, the output is (TV = Threshold value)	<ul style="list-style-type: none"> • TV above = 1 TV - hyst. below = 0 • TV above = 0 TV - hyst. below = 1 • <u>TV below = 1</u> TV + hyst. above = 0 • TV below = 0 TV + hyst. above = 1
Delays can be set via objects (in seconds)	<u>No</u> • Yes
Switching delay from 0 to 1 for setting via objects: valid until 1st communication	<u>None</u> • 1 s • 2 s • 5 s • 10 s • ... • 2 h
Switching delay from 1 to 0 for setting via objects: valid until 1st communication	<u>None</u> • 1 s • 2 s • 5 s • 10 s • ... • 2 h
Switching output sends	<ul style="list-style-type: none"> • <u>on change</u> • on change to 1 • on change to 0 • on change and periodically • on change to 1 and periodically • on change to 0 and periodically
Send cycle (is only sent if periodically is selected)	<u>5 s</u> • 10 s • 30 s... • 2 h

Blocking

The switching output can be blocked using an object. Define specifications here for the behaviour of the output when blocked.

Use switching output block	<u>No</u> • Yes
Analysis of the blocking object	<ul style="list-style-type: none"> • At value 1: block At value 0: release • At value 0: block At value 1: release
Blocking object value before first communication	<u>0</u> • 1
Behaviour of the switching output	
On block	<ul style="list-style-type: none"> • <u>Do not send message</u> • send 0 • send 1
On release (with 2 seconds release delay)	[Dependent on the "Switching output sends" setting]

The behaviour of the switching output on release is dependent on the value of the parameter "Switching output sends" (see "Switching output")

Switching output sends on change	<ul style="list-style-type: none"> • Do not send message • Send switching output status
Switching output sends on change to 1	<ul style="list-style-type: none"> • Do not send message • if switching output = 1 → send 1
Switching output sends on change to 0	<ul style="list-style-type: none"> • Do not send message • if switching output = 0 → send 0

Switching output sends on change and periodically	Send switching output status
Switching output sends on change to 1 and periodically	if switching output = 1 → send 1
Switching output sends on change to 0 and periodically	if switching output = 0 → send 0

5.10. Absolute humidity

The settings for the "absolute humidity" and other air humidity settings are only shown if the circuit board sensor input has been set to "temperature and humidity sensor" in the "General settings".

Decide which sensor is to be used for the calculation of absolute humidity. This selection also applies to the following comfort field settings.

Absolute humidity applies for (also applies to the comfort field)	<u>Plug-in sensor</u> • circuit board sensor
---	--

Activate the readings for absolute humidity and set the send pattern.

Use absolute humidity	<u>No</u> • Yes
Send pattern	<ul style="list-style-type: none"> • never • periodically • on change • on change and periodically
On change of (if sent on change)	0.1 g • 0.2 g • <u>0.5 g</u> • 1.0 g • 2.0 g • 5.0 g
Send cycle (if sent periodically)	5 sec • <u>10 sec</u> • 30 sec... • 2 hrs

5.11. Comfort field

The settings for the "comfort field" and other air humidity settings are only shown if the circuit board sensor input has been set to "temperature and humidity sensor" in the "General settings".

The settings made for "absolute humidity" regarding the relevant sensor also apply to the comfort field settings!

The **Interface KNX B8-TH** can send a message to the bus if the limits of the comfort field are exceeded. In this way, it is for example possible to monitor compliance with DIN 1946 (standard values) or even to define your own comfort field.

Use comfort field	<u>No</u> • Yes
-------------------	-----------------

Specify the **sending pattern**, a **Text** for comfortable and uncomfortable and the **Object value**.

Sending pattern	<ul style="list-style-type: none"> • <u>never</u> • periodically • on change • on change and periodically
Text for comfortable	[Free text max. 14 chars.]
Text for uncomfortable	[Free text max. 14 chars.]
Object value is at	<ul style="list-style-type: none"> • <u>comfortable = 1</u> <u>uncomfortable = 0</u> • <u>comfortable = 0</u> <u>uncomfortable = 1</u>
Send cycle (if sent periodically)	<u>5 s</u> • <u>10 s</u> • 30 s... • 2 h

Define the comfort field by specifying the minimum and maximum values for temperature and humidity. The specified standard values comply with DIN 1946

Maximum temperature in °C (Standard 26°C)	25 ... 40; <u>26</u>
Minimum temperature in °C (Standard 20°C)	10 ... 21; <u>20</u>
Maximum relative humidity in % (Standard 65%)	52 ... 90; <u>65</u>
Minimum relative humidity in % (Standard 30%)	10 ... 43; <u>30</u>
Maximum absolute humidity in 0.1 g/kg (Standard 115 g/kg)	50 ... 200; <u>115</u>

Temperature hysteresis: 1°C

Relative humidity hysteresis: 2% RH

Absolute humidity hysteresis: 2 g/kg

5.12. Variable comparator

The two integrated control variable comparators can output maximum, minimum and median values.

Use comparator 1/2	<u>No</u> • Yes
--------------------	-----------------

5.12.1. Control variable comparator 1/2

Determine what the control variable comparator should output, and activate the input objects to be used. Transmission patterns and blocks can also be set.

Output delivers	<ul style="list-style-type: none"> • Maximum value • Minimum value • <u>Average value</u>
Use input 1 / 2 / 3 / 4 / 5	No • Yes

Output sends	<ul style="list-style-type: none"> • <u>on change of output</u> • on change of output and periodically • when receiving an input object • when receiving an input object and periodically
Send cycle (if sent periodically)	5 s • 10 s • 30 s • ... • <u>5 min</u> • ... • 2 h
At and above change of (if sent on change)	1% • 2% • 5% • <u>10%</u> • 20% • 25% • 50%
Analysis of the blocking object	<ul style="list-style-type: none"> • <u>at value 1: block</u> at value 0: release • at value 0: block at value 1: release
Blocking object value before 1st communication	0 • 1
Behaviour of the switching output	
On block	<ul style="list-style-type: none"> • <u>do not send message</u> • Send value
Sent value in % output sends on release (with 2 seconds release delay)	0 ... 100 <ul style="list-style-type: none"> • <u>the current value</u> • the current value after receipt of an object

5.13. Logic

The device has 16 logic inputs, four AND and four OR logic gates.

Activate the logic inputs and assign object values up to 1st communication.

Use logic inputs	Yes • <u>No</u>
Object value prior to 1. Communication for:	
- Logic input 1	<u>0</u> • 1
- Logic input ...	<u>0</u> • 1
- Logic input 16	<u>0</u> • 1

Activate the required logic outputs.

AND logic

AND logic 1	<u>not active</u> • active
AND logic ...	<u>not active</u> • active
AND logic 4	<u>not active</u> • active

OR logic

OR logic 1	<u>not active</u> • active
OR logic ...	<u>not active</u> • active
OR logic 4	<u>not active</u> • active

5.13.1. AND logic 1-4 and OR logic outputs 1-4

The same setting options are available for AND and OR logic.

Each logic output may transmit one 1 bit or two 8 bit objects. Determine what the output should send if logic = 1 and = 0.

1. / 2. / 3. / 4. Input	<ul style="list-style-type: none"> • <u>do not use</u> - Logic inputs 1...16 - Logic inputs 1...16 inverted • all switching events that the device provides (see chapter <i>Connection inputs of AND and/or OR logic</i>)
Output type	<ul style="list-style-type: none"> • <u>a 1-bit-object</u> • two 8-bit objects

If the **output type is a 1-bit object**, set the output values for the various conditions.

Output value if logic = 1	<u>1</u> • 0
Output value if logic = 0	1 • <u>0</u>
Output value If block is active	1 • <u>0</u>
Output value if monitoring period is exceeded	1 • <u>0</u>

If the **output type is two 8-bit objects**, set the type of object and the output values for the various conditions.

Object type	<ul style="list-style-type: none"> • <u>value (0...255)</u> • Percent (0...100%) • Angle (0...360°) • Scene call-up (0...127)
Output value object A if logic = 1	0 ... 255 / 100% / 360° / 127; <u>1</u>
Output value object B if logic = 1	0 ... 255 / 100% / 360° / 127; <u>1</u>
Output value object A if logic = 0	0 ... 255 / 100% / 360° / 127; <u>0</u>
Output value object B if logic = 0	0 ... 255 / 100% / 360° / 127; <u>0</u>
Output value object A if block is active	0 ... 255 / 100% / 360° / 127; <u>0</u>
Output value object B If block is active	0 ... 255 / 100% / 360° / 127; <u>0</u>

Output value object A if monitoring period is exceeded	0 ... 255 / 100% / 360° / 127; <u>0</u>
Output value object B if monitoring period is exceeded	0 ... 255 / 100% / 360° / 127; <u>0</u>

Set the output send pattern.

Send pattern	<ul style="list-style-type: none"> • <u>on change of logic</u> • on change of logic to 1 • on change of logic to 0 • on change of logic and periodically • on change of logic to 1 and periodically • on change of logic to 0 and periodically • on change of logic+object receipt • on change of logic+object receipt and periodically
Send cycle (if sent periodically)	5 s • <u>10 s</u> • ... • 2 h

Blocking

If necessary, activate the block for the logic output and set what a 1 or 0 at the block input means and what happens in the event of a block.

Use block	<u>No</u> • Yes
Analysis of the blocking object	<ul style="list-style-type: none"> • <u>At value 1: block</u> At value 0: release • At value 0: block At value 1: release
Blocking object value before first call	<u>0</u> • 1
Output pattern On block	<ul style="list-style-type: none"> • <u>Do not send message</u> • Transmit block value [see above, Output value if blocking active]
On release (with 2 seconds release delay)	[Dependent on the "send pattern" setting]

The behaviour of the output on release is dependent on the value of the parameter "send pattern".

Output sends on change of logic	<ul style="list-style-type: none"> • Do not send message • transmit value for current logic status
Output sends on change of logic to 1	<ul style="list-style-type: none"> • Do not send message • if logic = 1 → send value for 1
Output sends on change of logic to 0	<ul style="list-style-type: none"> • Do not send message • if logic = 0 → send value for 0
Output sends on change of logic and cyclically	send value for current logic status
Output sends on change of logic to 1 and periodically	if logic = 1 → send value for 1
Output sends on change of logic to 0 and periodically	if logic = 0 → send value for 0

Output sends on change of logic and object receipt	<ul style="list-style-type: none"> • Do not send message • transmit value for current logic status
Output sends on change of logic and object receipt and periodically	Send value for current logic status

Monitoring

If necessary, activate the input monitoring. Set the inputs to be monitored and the cycle during which the inputs are to be monitored.

Use input monitoring	<u>No</u> • Yes
Input monitoring	<ul style="list-style-type: none"> • 1 • 2 • 3 • 4 • 1 + 2 • 1 + 3 • 1 + 4 • 2 + 3 • 2 + 4 • 3 + 4 • 1 + 2 + 3 • 1 + 2 + 4 • 1 + 3 + 4 • 2 + 3 + 4 • <u>1 + 2 + 3 + 4</u>
Monitoring period	5 s • ... • 2 h; <u>1 min</u>
Output behaviour on exceeding the monitoring time	<ul style="list-style-type: none"> • <u>Do not send message</u> • Send value exceeding [= value of the parameter "monitoring period"]

5.13.2.AND logic connection inputs

do not use

Logic input 1

Logic input 1 inverted

Logic input 2

Logic input 2 inverted

Logic input 3

Logic input 3 inverted

Logic input 4

Logic input 4 inverted

Logic input 5

Logic input 5 inverted

Logic input 6

Logic input 6 inverted

Logic input 7

Logic input 7 inverted

Logic input 8

Logic input 8 inverted

Logic input 9

Logic input 9 inverted

Logic input 10

Logic input 10 inverted

Logic input 11

Logic input 11 inverted

Logic input 12

Logic input 12 inverted

Logic input 13
Logic input 13 inverted
Logic input 14
Logic input 14 inverted
Logic input 15
Logic input 15 inverted
Logic input 16
Logic input 16 inverted
Plug-in sensor malfunction ON
Plug-in sensor malfunction OFF
Board sensor malfunction ON
Board sensor malfunction OFF
Switching output 1 Temperature
Switching output 1 Temperature inverted
Switching output 2 Temperature
Switching output 2 Temperature inverted
Switching output 3 Temperature
Switching output 3 Temperature inverted
Switching output 4 Temperature
Switching output 4 Temperature inverted
Switching output 5 Temperature
Switching output 5 Temperature inverted
Switching output 6 Temperature
Switching output 6 Temperature inverted
Switching output 7 Temperature
Switching output 7 Temperature inverted
Switching output 8 Temperature
Switching output 8 Temperature inverted
Switching output 1 Humidity
Switching output 1 Humidity inverted
Switching output 2 Humidity
Switching output 2 Humidity inverted
Switching output coolant temperature
Switching output coolant temperature inv.
Room temperature is comfortable
Room temperature is uncomfortable
Comfort temperature controller active
Comfort temperature controller inactive
Standby temperature controller active
Standby temperature controller inactive
Eco temperature controller active
Eco temperature controller inactive
Frost protection temperature controller active
Frost protection temperature controller inactive
Heating 1 temperature controller active
Heating 1 temperature controller inactive
Heating 2 temperature controller active
Heating 2 temperature controller inactive

Cooling 1 temperature controller active
 Cooling 1 temperature controller inactive
 Cooling 2 temperature controller active
 Cooling 2 temperature controller inactive
 Humidity controller de-humidification 1 active
 Humidity controller de-humidification 1 inactive
 Humidity controller de-humidification 2 active
 Humidity controller de-humidification 2 inactive
 Humidity controller humidification active
 Humidity controller humidification inactive

5.13.3. OR LOGIC connection inputs

OR logic connection inputs are the same as those of the AND logic. In addition the following inputs are available for the OR logic:

Switching output AND logic 1
 Switching output AND logic 1 inverted
 Switching output AND logic 2
 Switching output AND logic 2 inverted
 Switching output AND logic 3
 Switching output AND logic 3 inverted
 Switching output AND logic 4
 Switching output AND logic 4 inverted

5.14. Pushbutton interfaces

Activate the interfaces (inputs) that you want to use here. The **Interface KNX B8-TH** provides eight inputs.

Use interface 1/2/3/4/5/6/7/8

No • Yes

5.14.1. Interface 1...8

Interface inputs can be configured as switches, drive controller, dimmer, for transmitting values and for scenario recall/storage.

Function

- Switch
- Changeover switch
- Shutter
- Blinds
- Awning
- Window
- Dimmer
- 8-bit encoder
- 16-bit encoder
- Scene activation / scene saving

Input as switch:

If a button with switch function is assigned to the input, select the bus function "Switch" and specify which value is sent when pressing/releasing the button and when it will be sent.

Function	Switch
Command when pressing the button	<ul style="list-style-type: none"> • send 0 • <u>send 1</u> • do not send telegram
Command when releasing the button	<ul style="list-style-type: none"> • <u>send 0</u> • send 1 • do not send telegram
Send value	<ul style="list-style-type: none"> • <u>no change</u> • for change to 1 • for change to 0 • for change and cyclical • for change to 1 and cyclical • for change to 0 and cyclical
Cycle (if sent cyclical)	5 s • 10 s • 30 s • 1 min • 2 min • 5 min • 10 min • 20 min • 30 min • 1 h • 2 h

Input as changeover switch:

Select the "Changeover switch" bus function if a button with changeover function is assigned to the input.

Function	Changeover Switch
----------	--------------------------

Then decide whether an additional function is to be used if the button is held down.

Use additional function for button held down	<u>No</u> • Yes
--	-----------------

If **no additional function** is used for button held down, decide whether the changeover command is sent when pressing or when releasing the button.

Use additional function for button held down	No • Yes
Command when pressing the button	<ul style="list-style-type: none"> • Switching • <u>Do not send telegram</u>
Command when releasing the button	<ul style="list-style-type: none"> • Switching • <u>Do not send telegram</u>

If you are using the **additional function for button held down**, set the period between button tapped and button held down and what is to take place when the button is pressed and released at different times.

Use additional function for button held down	No • Yes
Time between tap and hold (in 0.1 sec)	0...50; <u>10</u>

Command when pressing the pushbutton	do not send telegram
Command when releasing before time expires	<ul style="list-style-type: none"> • <u>Switching</u> • Do not send message
Command when pressing the button	<ul style="list-style-type: none"> • Switching • send 0 • send 1 • <u>Do not send telegram</u>
Command when releasing the button	<ul style="list-style-type: none"> • Switching • send 0 • send 1 • <u>Do not send telegram</u>
Send behaviour	<ul style="list-style-type: none"> • <u>on change</u> • on change to 1 • on change to 0 • on change and periodically • on change to 1 and periodically • on change to 0 and periodically
Cycle (if sent periodically)	5 sec • 10 sec • 30 sec • 1 min • 2 min • 5 min • 10 min • 20 min • 30 min • 1 hr • 2 hrs

Input to shutter, blinds, awning or window control:

If the input to the drive control is used via the bus, select the bus function "shutter", "awning", "blinds" or "window" and specify the button function and control mode.

Function	Shutter / blinds / awning / window	
Button function	<u>Up</u> • Down <u>Up</u> • Down • Up/ Down <u>On</u> • Off • On/Off <u>Open</u> • Closed • Open/Closed	(shutter) (blinds) (awning) (window)
Control mode*	<ul style="list-style-type: none"> • <u>Standard</u> • Standard inverted • Comfort mode • Dead man's switch 	

*There is a detailed description of the setting options for the individual control modes in chapter ***Control modes for drive control, page 52.***

Input as dimmer:

If the input is used as a dimmer, select the bus function "Dimmer" and specify the button function, time interval (switching/dimming) and if requested, the repeat interval for a long button press.

Function	Dimmer
Button function	<u>brighter</u> • darker • brighter/darker

Time between switching and dimming (in 0.1 s)	1...50; <u>5</u>
Repeat the dimm command	<u>no</u> • yes
Repeat the dimm command for a long button press (if dimm command is repeated)	every 0.1 s • every 2 sec; <u>every 0,5 sec</u>
Dim by (if dimm command is repeated)	1,50% • 3% • <u>6 %</u> • 12,50% • 25% • 50%

Input 8 bit encoder:

If the input is to be used as an 8bit encoder, select the "8 bit encoder" bus function. Specify the range and which value will be sent.

Function	8 bit encoder
Range	<ul style="list-style-type: none"> • <u>0...255</u> • 0%...100% • 0°...360°
Value	[Depends on „Range“]

Input 16 bit encoder:

If the input is to be used as a 16bit encoder, select the "16 bit encoder" bus function and specify which value will be sent.

Function	16 bit encoder
Value in 0.1	-6707600...6707600; <u>0</u>

Input for scenario control:

If scenarios are recalled and stored with the input, select the bus function "Recall/save scenario" and define the storage, time difference (recall/storage) and the scenario number.

Function	Scenarios
Scenario no.	<u>0...63</u>
Scenario function	<ul style="list-style-type: none"> • <u>Recall</u> • <u>Recall and save</u>
Press key for longer than (in 01 s) Scenario saving (when "and save" is selected)	1... <u>50</u>

5.14.2. Control modes for drive control

If inputs are being used as switches to operate shades or windows, then various control modes can be set.

Control mode	<ul style="list-style-type: none"> • Standard • Standard inverted • Comfort mode • Dead man's switch
--------------	--

Standard:

If briefly operated, the drive will move incrementally or stops. If operated longer, the drive will move up to the end position. The time difference between "short" and "long" is set individually.

Control mode	Standard
Behavior during button operation: short = stop/increment long = Up or Down	
Time between short and long in 0.1 seconds	1...50; <u>10</u>

Standard inverted:

When pushed shortly, the drive moves up to the end position. When pushed for longer, the drive moves incrementally or stops. The time difference between "short" and "long" and the repeat interval is set individually.

Control mode	Standard inverted
Behavior during button operation: short = Up or Down long = Stop/Step	
Time between short and long in 0.1 seconds	1...50; <u>10</u>
Repeat the step command for a long button press	every 0.1 s • every 2 sec; <u>every 0.5 sec</u>

Comfort mode:

In the **comfort mode** pushing the button briefly, a bit longer and long will trigger different responses of the drive. The time intervals are set individually.

By pushing the button (shorter than adjustable time 1) the drive will be positioned (resp. stopped) incrementally.

If the drive is to be moved a bit farther, then a little longer push is needed (longer than time 1 but shorter than time 1+2). The drive stops immediately when releasing the button.

If the drive must be moved independently into the end position, the button is released only after times 1 + 2 have expired. The move can be stopped by briefly pushing.

Fig. 4

Time interval comfort mode diagram



Point in time 0:

Push of button, start of time 1

<i>Release before time 1 expired:</i>	<i>step (or stop if drive is moving)</i>
<i>Point in time 1:</i>	<i>End of time 1, start of time 2</i>
	<i>Moving command</i>
<i>Release after time 1 expired</i> <i>but before time 2 expires:</i>	<i>Stop</i>
<i>Release after time 1 + 2 expired:</i>	<i>Move into end position</i>

Control mode	Comfort mode
Behavior during button operation: Button is pushed and released before time 1 expired = stop/step held longer than time 1 = Up or Down released between time 1 and 1-2= stop released after time 1 +2 = no more stop	
Time 1	0.0s ... • 2 s; <u>0.4 s</u>
Time 2	0 s • 2 s; <u>2 s</u>

Dead man's switch:

The drive moves as soon as the button is pushed and stops as soon as the button is released.

Control mode	Dead man's switch
Behavior during button operation: Push button = Up or Down command Release button = Stop command	

